

**LFA0805 SERIES (LC Filter Array) Engineering Specification**



**1. Scope**

This specification is applicable to LC Filter Array series product. The customer designed part number drawing take precedence over this specification. The LC Filter Array is designed for EMI suppression application.

**Features:**

- SMD Type, 4 elements in one chip, 0805 size, suitable for high-density circuit design.
- Construction of dielectric and magnetic materials
- EMI filtering--steep insertion loss characteristics and removes noise over a wide range,
- Small Size and Low Profile
- PI( $\pi$ ) type structure filter

**Applications:**

- For Cellular Phone, Digital AV equipment, Digital Camera, PDAs and MP3 Player
- LCD Module/Display
- Wireless Handsets
- Lap Top Computer, Desk Top Computer and Notebook

**2. Part Number Code**

<u>LFA</u>	<u>0805</u>	<u>P</u>	<u>101</u>	<u>P</u>	<u>3</u>
(1)	(2)	(3)	(4)	(5)	(6)

- (1) Series name
- (2) Product size: 0805/EIA
- (3) Type: P— PI ( $\pi$ ) type
- (4) Cut-off frequency (MHz):  $XX \times 10^N$ , ex. : 100MHz=  $10 \times 10^1$  MHz  $\rightarrow$  101
- (5) Packaging: P - Embossed paper tape, 7" reel.
- (6) Thickness: 3 – 0.80 mm

**3. Specification**

**3.1 Electrical Property**

Part Number	Cut-Off Frequency @-3dB Typical	Attenuation Typical	Capacitance@1MHz (Reference)	Rated Current	Rated Voltage	Insulation Resistance @3VDC(min)
LFA0805P101P3	100 MHz	-30dB 800~1900 MHz -25dB 2000~2500 MHz	55pF	250 mA	12V	100 M $\Omega$
LFA0805P201P3	200 MHz	-30dB 1800~2500 MHz	17pF			

**Operation Temperature : -25 ~ +85°C**

### 3.2 Schematics

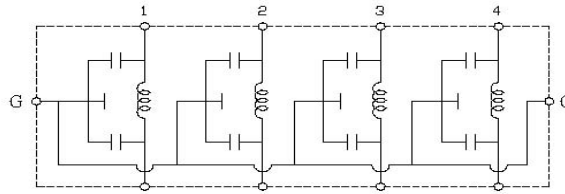

### 3.3 Attenuation characteristics

#### 3.3.1 Measurement circuit

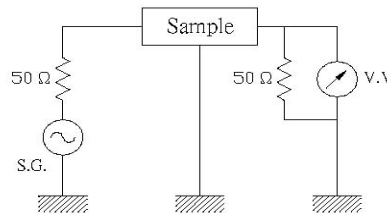

Typical insertion loss :

**LFA0805P101**

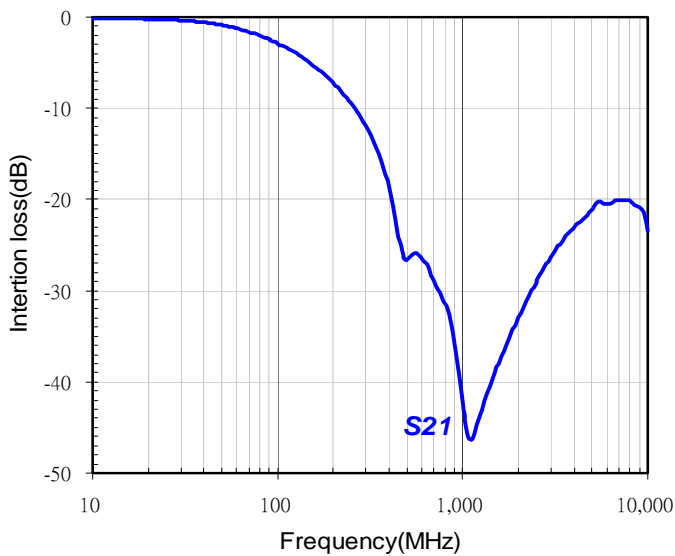

**LFA0805P201**

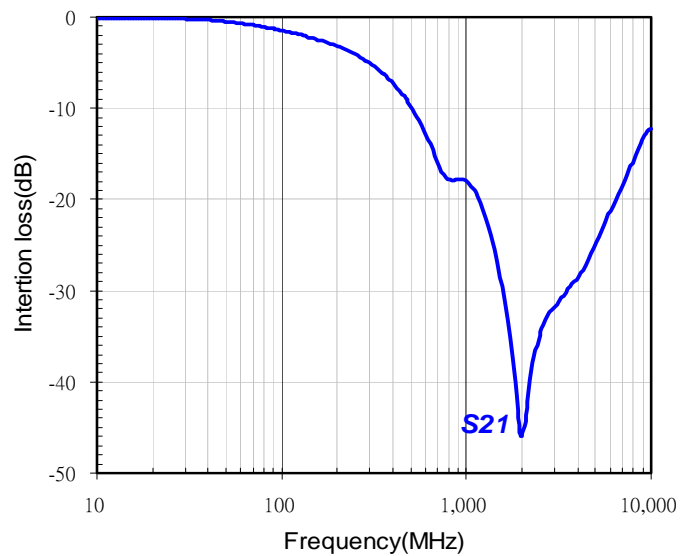

### 4. Dimensions and Marking Configuration

< Dimensions >

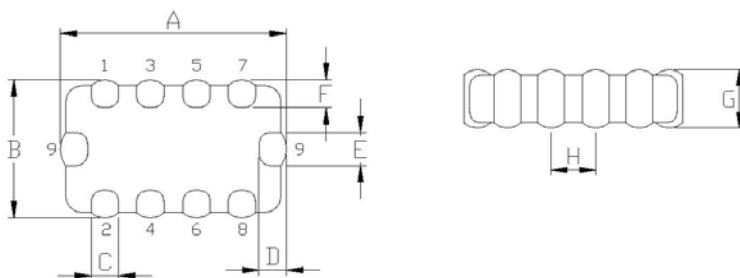

Unit: mm

LFA0805	P3
A	2.00±0.15
B	1.25±0.15
C	0.25±0.15
D	0.20±0.15
E	0.25±0.15
F	0.20±0.15
G	0.80±0.15
H	0.50±0.15

## 5. Performance Specifications

### 5-1. Standard condition

Unless otherwise specified, ambient atmosphere at performance tests and measuring shall meet the following conditions.

Ambient temperature :  $25 \pm 2 \text{ }^\circ\text{C}$

Relative humidity : 45 to 55%

Atmosphere pressure :  $0.87 \times 10^5$  to  $1.07 \times 10^5$  mmHg

### 5-2. Test method

Unless otherwise specified, the board, the land pattern, the flux, the solder, and the soldering method in performance tests shall be subjected to 3.3.1 of this specification.

### 5-3. Other Performance

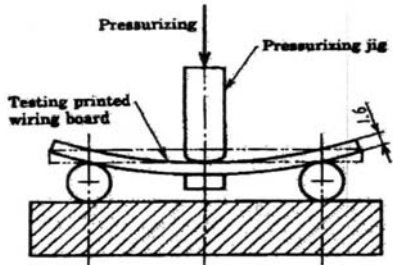
No.	Item	Specification	Test Condition															
1	Solderability	More than 95% of the terminal surface is to be soldered newly, so metal part does not or dissolve	Solder Temperature : $230 \pm 5^\circ\text{C}$ Dipping : 10 to 15 mm Depth Dip Time : $2 \pm 0.5$ sec. Solder : H63A Flux : Rosin Preheat : At $80 \sim 120 \text{ }^\circ\text{C}$ For 10~30sec.															
2	Resistance to board bending	Mount the device the testing printed wiring board. Then apply force in the direction shown in Fig.3. The bending stroke shall be 1mm. Pressurizing is carried out at the Rate of 1mm/s. After reaching the specified bending , keeping it for $5 \pm 1$ seconds. No cracking or marking defects shall occur	Unit: mm 															
3	Resistance to soldering heat	(a) 95% of the terminations is to be soldered evenly and continuously. (b) Appearance : No defect (c) Insertion Loss : 20% max	(a)The devices are dipped into the solder bath at $260 \pm 5^\circ\text{C}$ for $10 \pm 1$ seconds , then check the solderability by measuring the area covered (b)The devices should be taken into the solder bath at $260 \pm 5^\circ\text{C}$ for $10 \pm 1$ seconds. Set it at room temperature for $48 \pm 4$ hrs , then measure.															
4	Appearance	X8 magnification glass	No defect or abnormalities															
5	Dimension	Within the specified dimension	Using calipers															
6	Temperature cycle	Cut-Off Frequency Change within 20% Insulation Resistance : $100 \text{ M}\Omega$ Attenuation @ $< -30\text{dB}$ : 800~2000 MHz	Products shall be subjected to 5 cycles of the temperature cycle as following: <table border="1" data-bbox="981 1664 1390 1823"> <thead> <tr> <th>Step</th> <th>Temp.(<math>^\circ\text{C}</math>)</th> <th>Time (min)</th> </tr> </thead> <tbody> <tr> <td>1</td> <td><math>-40 +0/-3</math></td> <td>30</td> </tr> <tr> <td>2</td> <td>25</td> <td>3</td> </tr> <tr> <td>3</td> <td><math>85 +3/-0</math></td> <td>30</td> </tr> <tr> <td>4</td> <td>25</td> <td>3</td> </tr> </tbody> </table> Measure at room temperature after cooling for $24 \pm 4$ Hr.	Step	Temp.( $^\circ\text{C}$ )	Time (min)	1	$-40 +0/-3$	30	2	25	3	3	$85 +3/-0$	30	4	25	3
Step	Temp.( $^\circ\text{C}$ )	Time (min)																
1	$-40 +0/-3$	30																
2	25	3																
3	$85 +3/-0$	30																
4	25	3																

**6. Taping Package and Label Marking**

**6-1. Packaging method**

Products shall be heat-sealed in the chip pocket, spacing pitch 4-mm of Paper/plastic carrier tape with cover tape, and the tape shall be reeled to the reel.

**6-2. Label Marking**

The label specified as follows shall be put on the side of reel.

- (1) Part No.
- (2) Quantity
- (3) Lot No.

\* Part No. And Quantity shall be marked on outer packaging.

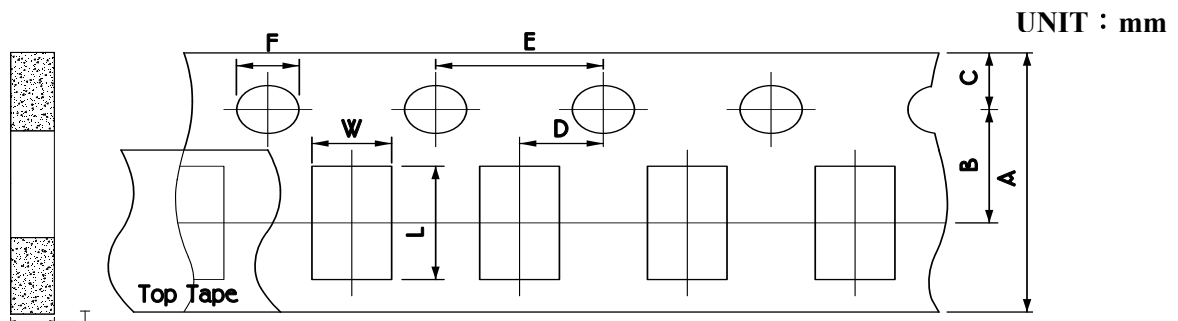

symbol type	1	A	B	C	D	E	F	W	T (P3)	L
Dimension	8.0 ±0.3	3.5 ±0.05	1.75 ±0.1	2.0 ±0.05	4.0 ±0.1	1.5 +0.1	1.65 ±0.2	0.95 ±0.05	2.4 ±0.2	

**6-3. Taping reel dimensions**

- Standard Packing Quantity per Reel (  $\phi$  178 )
- Cardboard paper Tape: 4,000 pcs

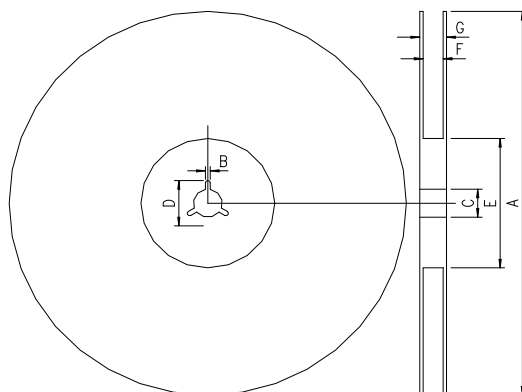

	Unit: mm
A	178.0±2.0
B	2.00±0.5
C	13.0±0.5
D	21.0±0.8
E	60.0±1.0
F	9.00±0.5
G	12.0±0.2

**7. Precautions for Handling**

**7-1. Recommendable land pattern is referred the following drawing, for example.**

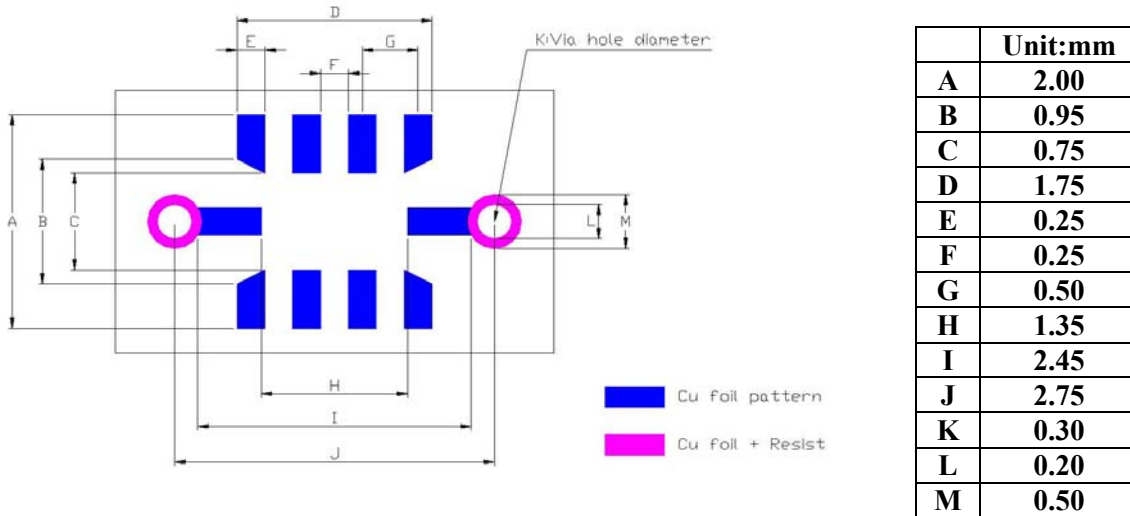

**7-2. Solder cream in reflow soldering**

- (1) Refer to the recommendable land pattern as printing mask pattern for solder cream.
- (2) Print solder in a thickness of 150 to 200 μm.

**7-3. Precaution for handling of substrate**

Do not exceed to bend the board after soldering this product extremely.

(Reference examples)

- Mounting place must be as far as possible from the position, which is close to the break line of board, or on the line of large holes of board.
- Do not bend extremely the board, in mounting another component.  
If necessary, use back-up pin (support pin) to prevent from bending extremely.
- Do not break the board by hand. We recommend using the machine or the jig to break it.

**7-4. Precaution for soldering**

Note that this product will be easily damaged by rapid heating or rapid cooling or local heating.

Do not give heat shock over 100°C in the process of soldering. We recommend to take preheating and gradual cooling.

### 7-5. Recommendable reflow soldering

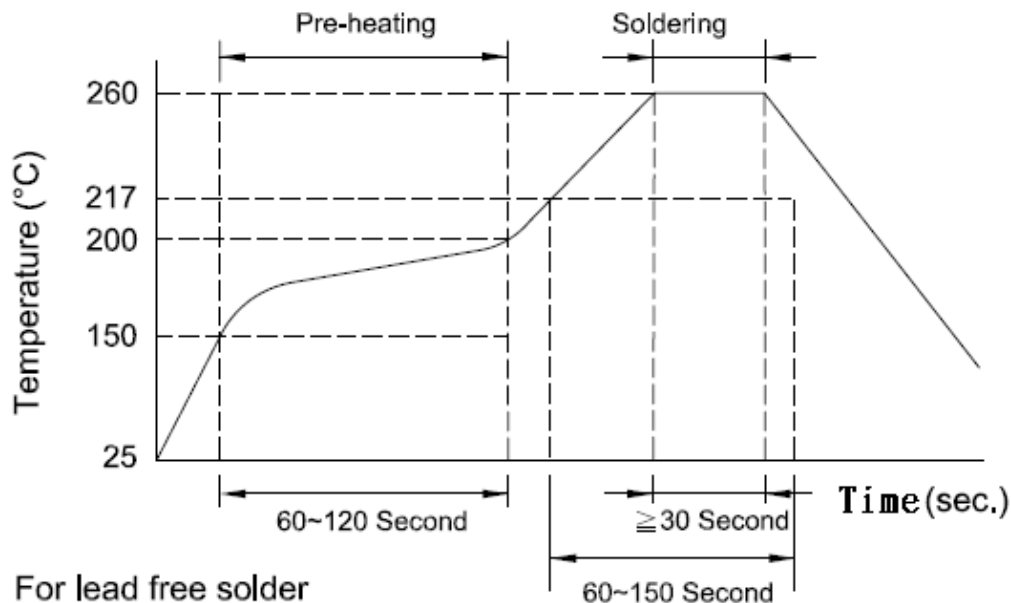

### 7-6. Caution of flow soldering

We can not recommend the flow soldering to this product, because we afraid that solder bridge happens owing to narrow 0.8mm pitch of this product.

### 7-7. Soldering gun procedure

Note the follows, in case of using solder gun for replacement.

- (1) The tip temperature must be less than 280°C for the period within 3 seconds by using soldering gun under 30 W.
- (2) The soldering gun tip shall not touch this product directly.

### 7-8. Soldering volume

Note that excess of soldering volume will easily get crack the body of this product.

### 7-9. Storage conditions

Note the follows, in case of storing this product.

- (1) Avoid the atmospheres which are high temperature, high humidity, dusty and having corrosive gas (Hydrogen chloride, Sulfurous acid gas, Hydrogen sulfide etc.) to prevent terminal solderability from declining.  
Keep the storage conditions less than 40°C and 70% relative humidity, and use up this product in six months as far as you can.
- (2) Avoid direct heat and sunshine to prevent the tape of package from transforming and sticking to this product.